

METMO

Simply Moves



White



Black



Silver

eFLEX-F2-US

- | Sixfold width adjustable
- | Unique leg shaping and design
- | Clean, crisp design
- | Dual-stage
- | Basic or comfort handset
- | 3 standard colors
- | Intelligent System Protection
- | 2 integrated sensors
- | Brushless motor technology
- | Ultra-quiet operation
- | Constant speed
- | Plug & Play technology
- | Simple & fast set up
- | Compact & e-Commerce designed packaging
- | **Made in EU**

The eFLEX family is a range of adjustable frames that represents the perfect package for retailers and end users. Optimized for e-commerce – with flawless user experience, technology and stunning design – each frame adjusts perfectly to the needs of your business and customers. Choose between fixed-width (S-Series) and adjustable-width (F-Series) versions to suit whatever design you have in mind.

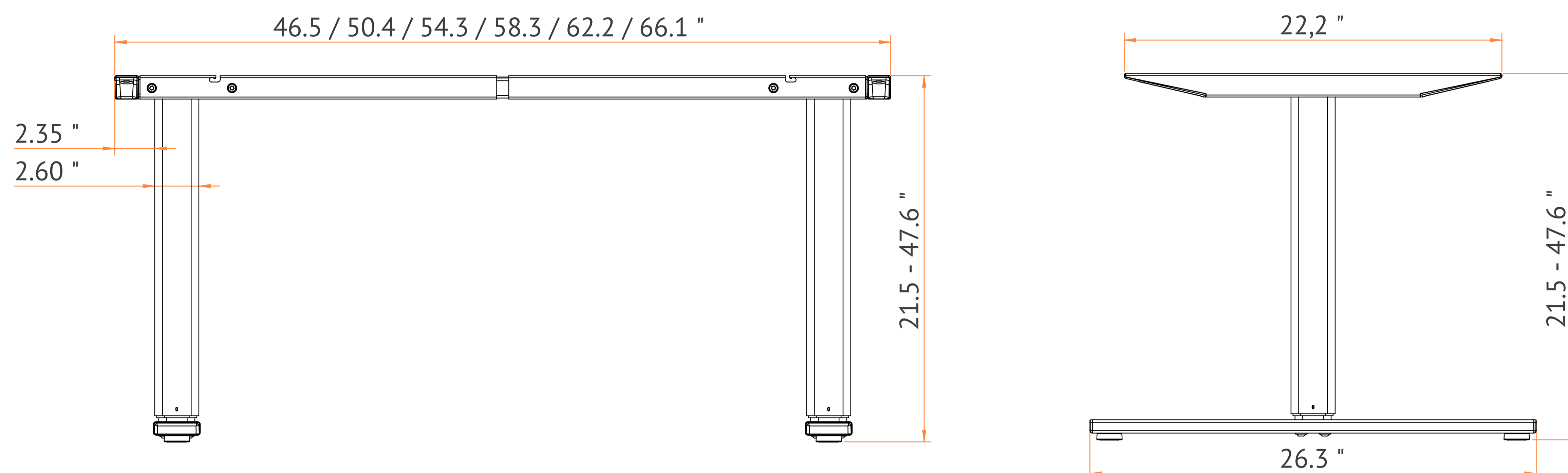

Technical Data eFLEX-F2-US

Stroke

26.1 inch | 663 mm

Travel range (without tabletop)

21.5- 47.6 inch | 547 - 1210 mm

Lifting capacity (without tabletop)

220.5 lbs | 100 kg

Adjustment speed

1.5 inch/s | 38 mm/s

Weight (Frame)

51 lbs | 23 kg

Dimensions (Packaging)

44.9 x 7.5 x 8.9 inch | 1140 x 190 x 225 mm

Weight (Packaging)

57 lbs | 26 kg

Handset Options

DMUI-HSM | DMUI-HSU

Ambient conditions during transport and storage

Temperature between -35°C and 85°C

Temperature over 50°C only for periods not exceeding 72h

Maximum relative humidity between 95% and 5%
(lower allowed)

Ambient conditions during operation

Temperature between 5°C and 40°C

Maximum relative humidity between 95% and 68%
(lower allowed)

Certificates & Standards

UL 962 Edition 4

Title 47 CFR Part 15 Subpart B

BIFMA X5.5 +G1

Available Colors

White

Black

Silver

Order Code

eFLEX-F2-US-WHT-STD-00

eFLEX-F2-US-BLK-STD-00

eFLEX-F2-US-SLV-STD-00