

# METMO

Simply Moves



White



Black



Silver

## eFLEX-F2-EU

- | Sixfold width adjustable
- | Unique leg shaping and design
- | Clean, crisp design
- | Dual-stage
- | Basic or comfort handset
- | 3 standard colors
- | Intelligent System Protection
- | 2 integrated sensors
- | Brushless motor technology
- | Ultra-quiet operation
- | Constant speed
- | Plug & Play technology
- | Simple & fast set up
- | Compact & e-Commerce designed packaging
- | **Made in EU**

The eFLEX family is a range of adjustable frames that represents the perfect package for retailers and end users. Optimized for e-commerce – with flawless user experience, technology and stunning design – each frame adjusts perfectly to the needs of your business and customers. Choose between fixed-width (S-Series) and adjustable-width (F-Series) versions to suit whatever design you have in mind.

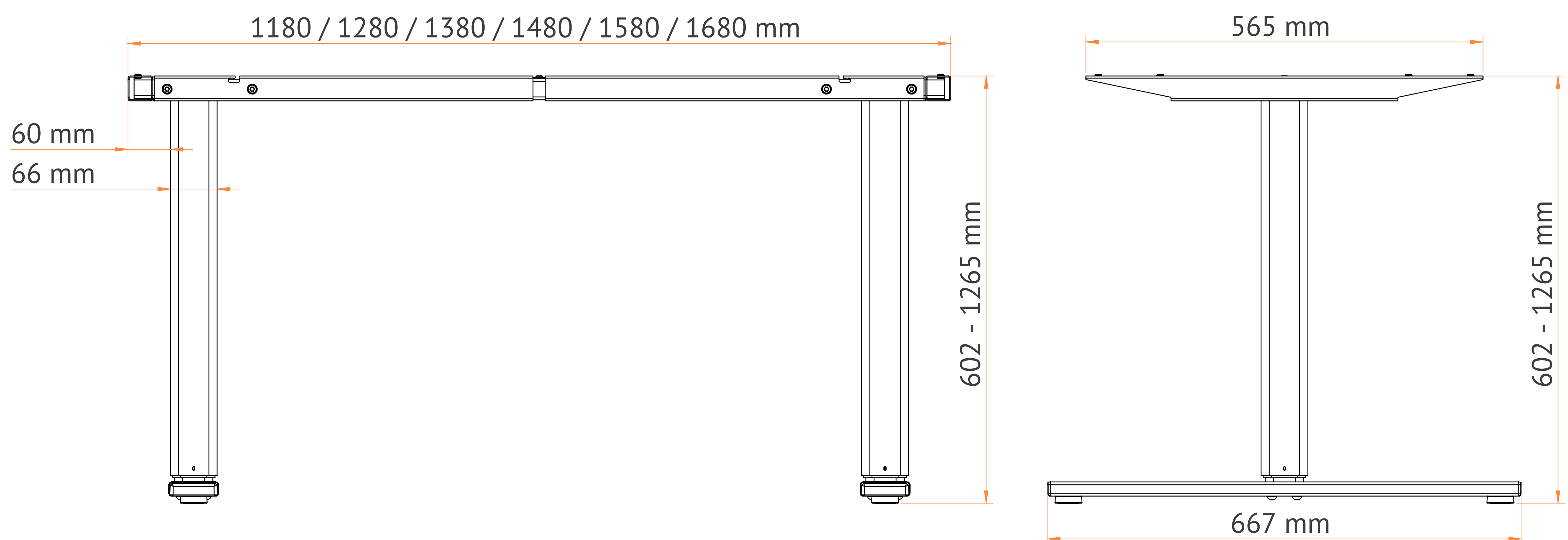

## Technical Data eFLEX-F2-EU

### Stroke

663 mm

### Travel range (without tabletop)

602 - 1265 mm

### Lifting capacity (without tabletop)

100 kg

### Adjustment speed

38 mm/s

### Weight (Frame)

23 kg

### Dimensions (Packaging)

1140 x 190 x 225 mm

### Weight (Packaging)

26 kg

### Handset Options

DMUI-HSM, DMUI-HSU

### Ambient conditions during transport and storage

Temperature between -35°C and 85°C

Temperature over 50°C only for periods not exceeding 72h

Maximum relative humidity between 95% and 5%

(lower allowed)

### Ambient conditions during operation

Temperature between 5°C and 40°C

Maximum relative humidity between 95% and 68%

(lower allowed)

### Certificates & Standards

EN ISO 12100:2013 | DIN EN ISO 13854: 2020 01 |

EN 60335-1:2012 | EN 527-1:2011 05 |

EN 527-2:2016+A1:2019-05 | EN 62233:2008 |

EN IEC 61000-6-1:2019 | EN 61000-6-3/A1:2011 03 |

EN 61000-3-2:2014 | EN 61000-3-3:2014 | ISO 13849-1:2015 |

ISO 13849-2:2013, PLb | AfPS GS 2019:01 - PAH

### Available Colors

White

Black

Silver

### Order Code

eFLEX-F2-EU-WHT-STD-00

eFLEX-F2-EU-BLK-STD-00

eFLEX-F2-EU-SLV-STD-00